

ITF report: the state of the game 2018

Jamie Capel-Davies and James Spurr (ITF)

ITF Coaching and Sport Science Review; 78 (27): 16-20

ABSTRACT

In order to fulfil its mission of protecting the nature of tennis and encouraging innovation and improvements, the ITF Technical Centre quantifies the parameters that describe the essence of the sport at the elite level, and thus constitute ‘the state of the game’. This annual report aims to establish how players, their equipment and the interaction between them are changing over time, to analyse the impact of these changes on the game and to contemplate the merits of any necessary counter-measures. Point length is a key metric of the nature of the game. Too many short points is generally considered unattractive. Low serve returnability can lead to short points, therefore serve returnability should be monitored and understood. Serve returnability is strongly dependent on post-bounce speed, serve angle and the proximity of the bounce to the centre serviceline or sideline. Taller players typically serve faster than shorter players and therefore generate higher post-bounce speeds, lower returnability serves and consequently more short points. The higher post-bounce speed of serves by these players can be reduced, increasing their returnability, by using a slower court and/or larger ball. A warning indicator signalling an excessive number of short points could be used to determine when regulation of equipment might be used to counteract the rise of shorter points. A more radical response would be to make the service-box narrower to increase the returnability of serves without impacting the speed of subsequent shots. .

Key words: elite tennis, technical, notational analysis

Corresponding author: technical@itftennis.com

Article received: 13 June 2019

Article accepted: 19 July 2019



- Point length is measured by the number of shots in a point. A match that consists mainly of very short points is undesirable as it risks being reduced to a serving contest. Conversely, a match that consists of too many very long points can become tedious. Point length is dependent on serve dominance, the players' (relative) ability and tactics, and ball speed.
- Point quality is defined by the 'style' of play, which includes the location of the players on the court (i.e. proximity to the net or baseline and sidelines), shot selection and frequency of winners and errors.
- Set length is measured by the number of points in a set and is dependent on the number of points in a game and games in a set. If the serve is dominant, then points and games will be short but there will tend to be more games in the set since neither player can break serve. If one player is significantly superior, both the games and sets will be short.
- Set quality is determined by the proportion of important points in the set (i.e. those points that strongly affect the outcome of the match). For example, break points are typically important points. Hence, set quality is also dependent on serve dominance and the relative ability of the players.

This report focuses on point length, examining the factors that influence point length, how they are changing over time and how they might be regulated if deemed necessary.

INTRODUCTION

In order to fulfil its mission of protecting the nature of tennis and encouraging innovation and improvements, the ITF Technical Centre quantifies the parameters that describe the essence of the sport at the elite level, and thus constitute 'the state of the game'. This annual report aims to establish how players, their equipment and the interaction between them are changing over time, to analyse the impact of these changes on the game and to contemplate the merits of any necessary counter-measures.

The following quotes were made two decades ago, but remain relevant and contextualise the purpose of the state of the game report:

"I think you have to look at what it will be like in 10 years down the road. I have seen some statistics that say that in one big final last year 54% of the points finished after the first two strokes. I don't think there's anything pretty to look at there." - Ivan Lendl.

"The big guys have an edge... We should not be frightened of changing the rules if it developed so that 90% of the top 50 were more than 6'6" (198 cm) and that finesse was being lost." - John Newcombe.

The following four metrics are believed to be key characteristics of the game that appeal to spectators and influence players' satisfaction and enjoyment:

POINT LENGTH

Point length is dependent on serve dominance. At the extreme, a winning serve has a point length of one. Successful serve and volleying have a point length of three. There is an inverse relationship between the length of a point and the impact of the serve on the outcome, as shown in figure 1. Understanding the returnability of a serve (defined as the probability it will be successfully returned 'in') enables the prediction of point length.

Serve returnability

Nearly 40,000 men's serves from Davis Cup matches played on acrylic and grass courts in the past seven years were analysed

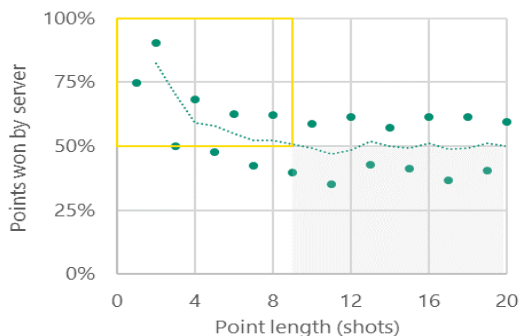

Figure 1. Percentage of points won by the server against point length in selected Davis Cup matches. Dotted trendline is a moving average of two periods.

to identify the critical determinants of their returnability¹. The serves were clustered into 80 groups of similar characteristics, based on 305 trajectory features (e.g. height of impact, initial speed). This method created a continuum of serve returnability (from the binary 'returned' or 'unreturned' outcomes). In doing so, the factors associated with high/low returnability could be isolated. Figure 2 shows the returnability of each cluster. The cluster returnability scores ranged from 22% (i.e. the types of serves in this cluster had a low probability of being returned) to 88%.

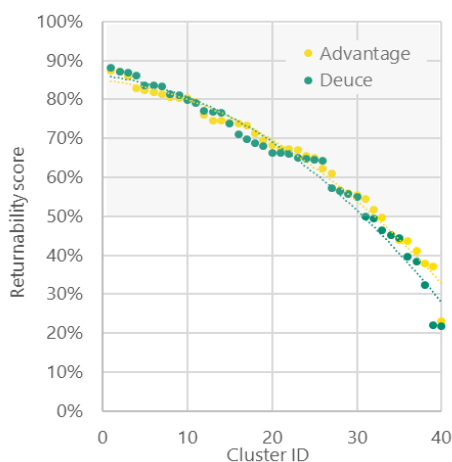

Figure 2. Returnability scores for each of the 40 serve clusters for the deuce court (green) and advantage court (yellow).

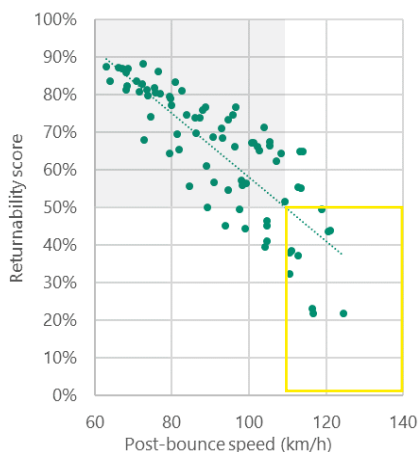

Figure 3. Returnability scores for each of the 80 serve clusters against post-bounce speed.

¹ The same analysis will be applied to women's serves in the Fed Cup.

Three key factors were identified using regression analysis: serve angle (i.e. the angle between direction of the serve and the position of the receiver), proximity of the ball bounce location to a long line (sideline or centre serviceline), and post-bounce ball speed. Figure 3 shows a negative linear correlation between post-bounce speed and returnability: as post-bounce speed increases by 1 km/h returnability decreases by almost 1%. Above a post-bounce speed of 110 km/h, the returnability score tends to be below 50%. A receiver facing a serve with a high post-bounce speed has less time to respond and must control the speed of the incoming ball. Several variables can contribute to a higher post-bounce speed, including a greater serve speed, a smaller ball (which generates less drag) and a faster court pace rating (CPR). A 1 km/h change in post-bounce speed is equivalent to around 2 CPR points.

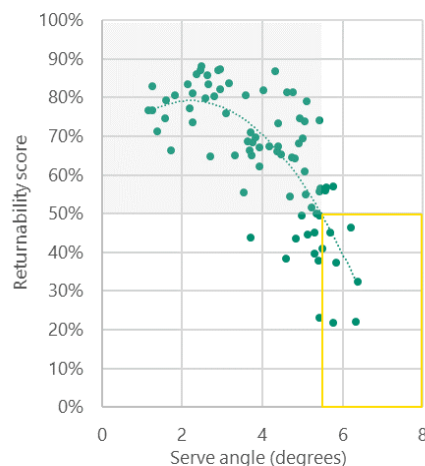

Figure 4. Returnability scores for each of the 80 serve clusters against serve angle.

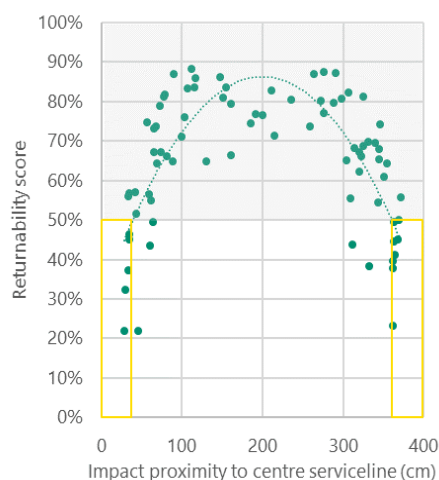

Figure 5. Returnability scores for each of the 80 serve clusters against proximity of the impact to the centre serviceline.

Figure 4 shows a non-linear relationship between serve angle and returnability. A receiver facing a serve with a higher serve angle has further to travel to reach the ball (and therefore less time to play their shot). Below a serve angle of approximately 3 degrees, there is not a strong effect of serve angle on returnability, but above 3 degrees the decrease in returnability is sharp. Above 5.5 degrees, the returnability score tends to be below 50%. Figure 5 shows a non-linear relationship between proximity of the bounce location to a long line and returnability. Returnability is lower when the ball lands close to a long line (within 40 cm). Receivers typically stand near to the midpoint of the advantage or deuce courts. Therefore, they have less time to play their return when the serve bounces close to centre serviceline or the sideline. Wide serves will typically have a larger serve angle and land close to the sideline, making them lower-returnability serves (provided they are not too slow).

When a server exploits all three critical determinants, serves have very low returnability. 'Super-serves' had a post-bounce speed of at least 110 km/h, a serve angle of at least 5.5 degrees and proximity to the centre serviceline of 40 cm, or less. These serves had a returnability of 20%, or one in five serves, which is enough to comfortably win a service game if produced consistently.

Player analysis

Figure 6 shows a positive linear correlation between first serve speed and player height. Taller players typically have a greater arm span, which produces a higher racket head speed (for a constant swing speed), and consequently a faster serve. Figure 7 shows a positive linear correlation between post-bounce speed and player height: faster serves, from taller players, result in high post-bounce speeds. Although serve speed cannot be moderated, post-bounce speed can be reduced through use of a larger ball and/or slower surface.

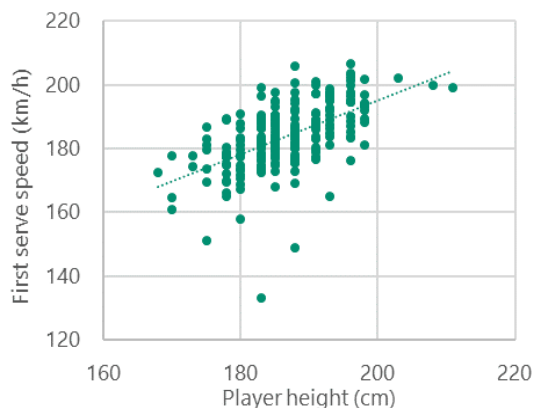

Figure 6. Average first serve speed against player height.

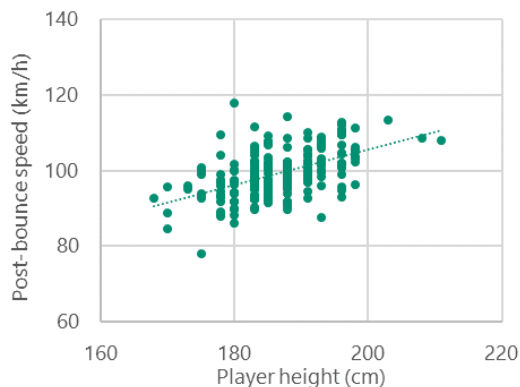

Figure 7. Average post-bounce speed against player height.

Figure 8 shows that the average heights of the top 50 women and men have increased since 2002, by 2 cm and 3 cm respectively. This increase in the average height of the men was due to the number of players over 200 cm tall who are currently active (prior to 2007 there were none) and a general increase in height across all 50 players (see figure 9). In 2002, women in the top 50 were 12 cm shorter, on average, than their male counterparts. This difference has remained reasonably consistent and is now 13 cm. The tallest woman in the current top 50 is the same height as the average height of the top 50 men (188 cm).

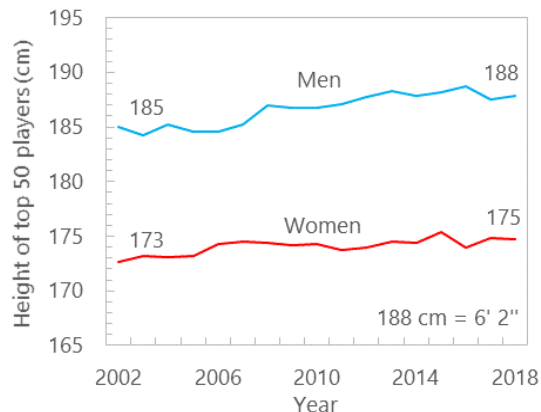

Figure 8. Average height of the top 50 women (red) and men (blue).

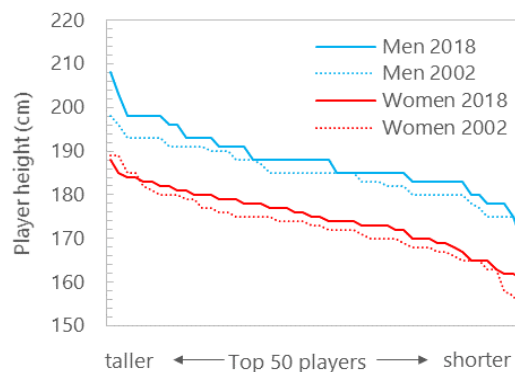

Figure 9. Individual heights of the top 50 women (red) and men (blue) in 2002 and 2018.

To summarise, taller players have an advantage over shorter players, because their additional height enables them to serve faster, and several of them have made it into the men's top 50 (possibly because of this edge). Player height cannot be capped, but the associated advantage of serve speed can potentially be attenuated by making changes to reduce post-bounce speed. Shorter players are less likely to be affected by these changes as they tend to serve slower in the first place.

Longitudinal analysis

The Grand Slam tournaments are a valuable gauge for assessing longitudinal changes in the sport as they have consistently strong draws, include a variety of surface types (with differing court pace) and inform many people's view of the game due to their high profile. Analysis of shot returnability and point lengths in these competitions is not currently possible due to a lack of data. In the absence of those data, other metrics, such as ace rates and serve points won, are used as proxies.

Figure 10 shows that, with the exception of the Australian Open, the incidence of aces has been stable at the Grand Slams. Higher ace rates contribute to lower serve returnability. The ace rates at Wimbledon have been roughly double those at Roland Garros. This demonstrates the influence of the speed of the court, as grass has the highest CPR of the Grand Slam surfaces and clay the lowest. Throughout the period analysed, men served aces at twice the rate of women. This would suggest that points were generally shorter at Wimbledon than at Roland Garros and that men's points were shorter than women's points.

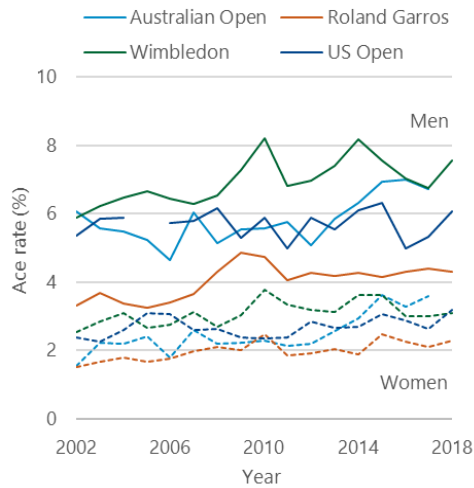

Figure 10. Percentage of aces per serve in Grand Slam singles matches.

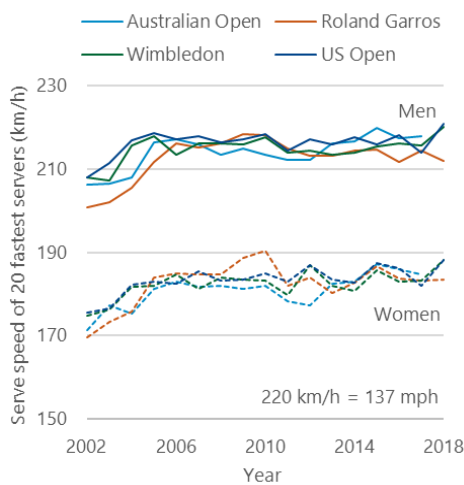

Figure 11. Average serve speed for the fastest 20 servers in Grand Slam singles matches.

Analysis of serve speeds at the Grand Slam events shows that the fastest serves of the top 20 fastest-serving men and women have increased since 2002 (see figure 11). However, most of this increase was between 2002 and 2005. Over the past decade, the top 20 fastest serving men served, on average, at 215 km/h and the women at 185 km/h.

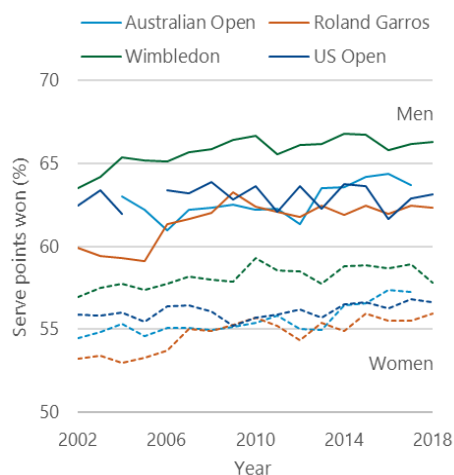

Figure 12. Percentage of points won on serve in Grand Slam singles matches.

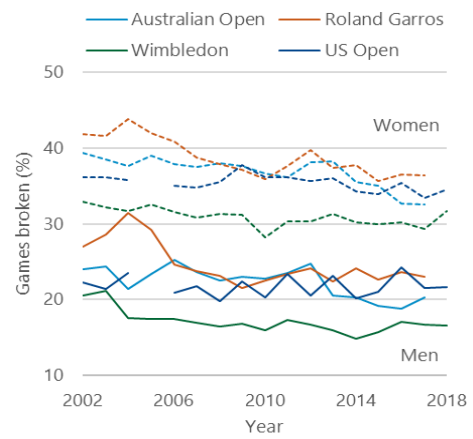

Figure 13. Percentage of games broken in Grand Slam singles matches.

Figure 12 shows that points won by the server is generally increasing over time and is highest at Wimbledon. It is therefore likely that returnability of serves at Wimbledon is lowest too (as indicated by the high ace rate). Remarkably, although the aces served at Roland Garros were less frequent (figure 10), the serve points won have been comparable to those at the US Open. Serve points won at the Australian Open have been gradually increasing for both men and women. One explanation for this trend could be a change in court pace over time, but this has not been verified. Figure 13 shows the percentage of service games broken each year, the decreasing trend in which is largely the inverse of serve points won. The serve has been less dominant in the women's game than it has been in the men's game. If serve returnability is low, the frequency of games broken is typically low. In the past 10 years, the average percentage of games broken in men's matches has been less than 25% at all of the Grand Slams and below 20% at Wimbledon.

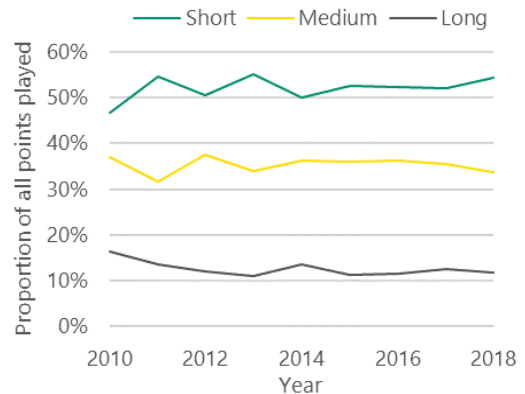

Figure 14. Percentage of short (less than 4 shots), medium (4-8 shots) and long (more than 8 shots) points played by men in selected ties in Davis Cup.

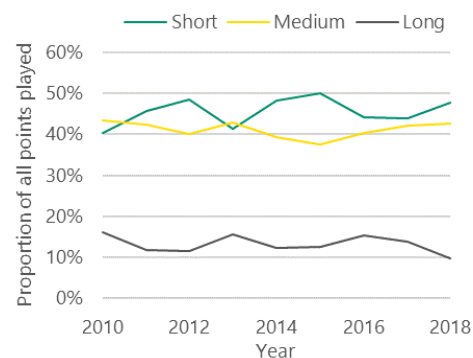

Figure 15. Percentage of short (less than 4 shots), medium (4-8 shots) and long (more than 8 shots) points played by women in selected ties in Fed Cup.

Figure 14 shows that typically more than half of points in the selected Davis Cup ties were 'short' (less than 4 shots) and just over 10% were 'long' (more than 8 shots). In the Fed Cup there were fewer short points and more 'medium-length' points (4-8 shots), as illustrated in figure 15. This is consistent with the predicted difference in point length between men and women for the Grand Slams. There was no identifiable trend of increasing or decreasing point length in the past 8 years in either competition. If it were to be agreed that short points are undesirable, it would be possible to establish a warning indicator at a particular level. For example, if the proportion of short points were to exceed that level in consecutive years, then action could be taken to reduce the incidence of short points. For instance, regulation could be introduced to increase the returnability of the serve. This could include use of slower court surfaces and/or larger balls. Alternatively, the size of the service box could be reduced by the creation of 'side servicelines' (see figure 16). This modification is more radical but would target the returnability of serves only and not affect other shots (which would be impacted if ball size was increased).

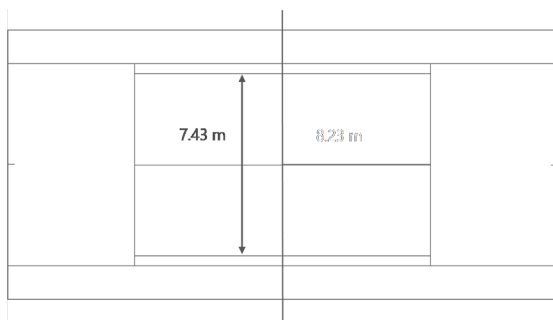

Figure 16. Court markings with the introduction of side service lines, which are on each side of the centre serviceline and run parallel to it 7.43 m apart from one another.

CONCLUSION

Point length is a key metric of the nature of the game. Too many short points is generally considered unattractive. Low serve returnability can lead to short points, therefore serve returnability should be monitored and understood. Serve returnability is strongly dependent on post-bounce speed, serve angle and the proximity of the bounce to the centre serviceline or sideline. Taller players typically serve faster than shorter players and therefore generate higher post-bounce speeds, lower returnability serves and consequently more short points. The higher post-bounce speed of serves by these players can be reduced, increasing their returnability, by using a slower court and/or larger ball. A warning indicator signalling an excessive number of short points could be used to determine when regulation of equipment might be used to counteract the rise of shorter points. A more radical response would be to make the service-box narrower to increase the returnability of serves without impacting the speed of subsequent shots.

REFERENCES

- Capel-Davies, J. (2017) "Tennis at the elite level – An ITF technical centre review". ITF Coaching and Sports Science Review. 73 (25), pp. 3-5.
- Coe, A. (2000). The balance between technology and tradition in tennis. In *Tennis Science & Technology* (edited by S. Haake), pp. 3-40. London: International Tennis Federation
- Hext, A., & Choppin, S. (2019). Modelling serve returnability in tennis using Hawk-Eye data. Unpublished report supplied to the International Tennis Federation.

[RECOMMENDED ITF TENNIS COACH CONTENT \(CLICK BELOW\)](#)

